

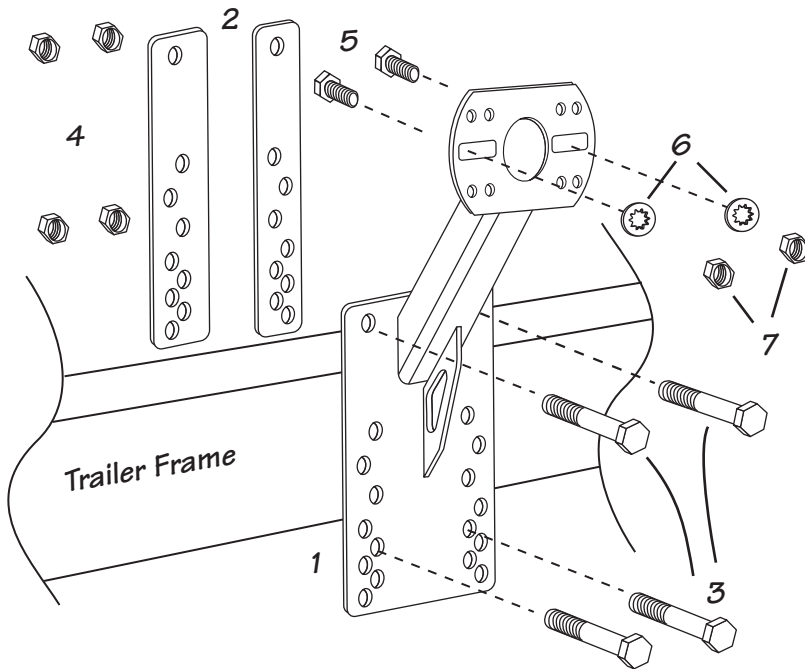

best in the  
**LongRun**

# Heavy Duty Side Mount Spare Tire Carrier

Assembly/Installation Instructions  
Part #86069



This kit contains the following components:

#	Qty.	Part #	Description
1	1	45077	Spare Tire Carrier
2	2	45077-4	Backing Plates
3	4	10813	Hex Head Bolts 1/2"-13 x4-1/2"
4	4	10645	Nylock Nuts 1/2"-13
5	2	10863	Carriage Bolts 1/2"-20 x 1-3/4"
6	2	10640	Bolt Retainer 1/2"
7	2	10641	Lug Nuts 1/2"-20

1. Using the spare tire carrier and spare tire as a guide determine a suitable mounting location on the trailer frame.
2. Slide bolt through front (top) tire carrier, over the frame and through the mounting bracket. Use the bolt pattern that fits closest to the frame. Loosely mount with washers and nuts provided. Repeat #2 for the opposite mounting bracket.
3. Using the spare tire to determine the correct holes to use, place the carriage bolts provided for mounting the spare tire in the holes of the rectangular plate. Bolt heads should be on the back side of the tire carrier. Secure bolts with "star" washers.
4. Check position of the tire mount for proper clearance with the spare tire before tightening bolts.
5. Once position is determined tighten all (4) mounting bolts/nuts.
6. Mount spare tire and tighten lug nuts.

Instruction Sheet #08105

**TIE DOWN ENGINEERING • 255 Villanova Drive SW • Atlanta, GA 30336**  
**www.tiedown.com (404) 344-0000 Fax (404) 349-0401**



AB42: 051316