

# Installation Instructions

## LT22 Backpack Blower Rack

for Landscape Trailers

Designed to fit the following:

Stihl® BR-340

Stihl® BR-340

Before you begin installing:

1. Read and understand these instructions completely.
2. Verify that you have received all the parts listed in the bill of materials.

### CAUTION

Always wear safety glasses when using power tools.

## Utility Trailer Installation

### Tools Required:

- (2) 9/16" Wrenches and/or Sockets
- Electric Drill
- 13/32" Drill Bit
- Carpenters Square

1. Clamp the blower rack to the trailer side rail with the base of the upright on the trailer floor. Verify the rack is square to the trailer deck in both directions with a carpenter's square.
2. After determining the position of the rack, mark center of the two holes in the base on the trailer floor.
3. Remove the rack from the trailer and use a 13/32" drill bit to drill two holes in your trailer deck as marked.
4. Assemble the rack to the trailer with two 3/8-16 x 2-1/2" cap screws, four 3/8" flat washers and two 3/8-16 nylock nuts. **Do not tighten screws at this time.**
5. Clamp the blower rack to the rail of the trailer. Make sure the rack is square to the rail and the deck

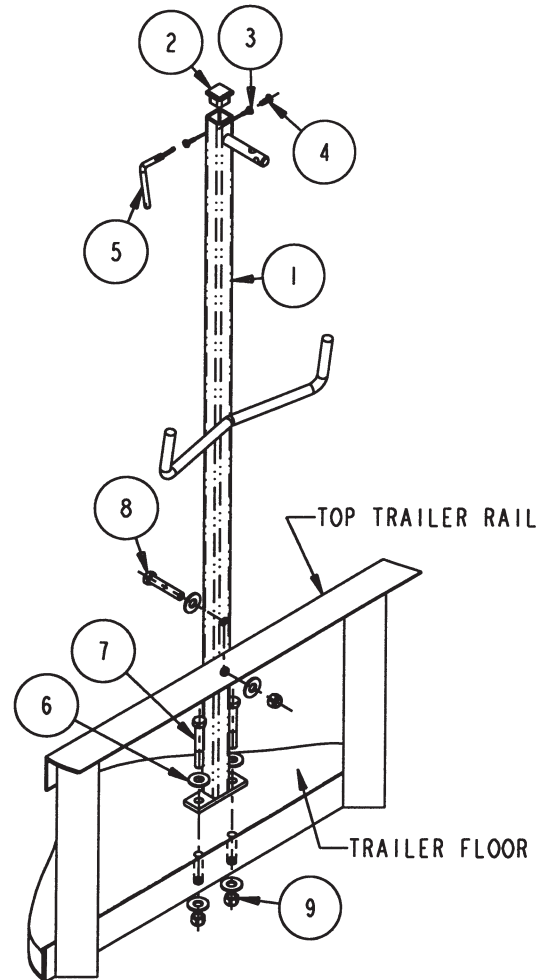

## Bill of Materials

ITEM	PART NO.	QTY.	DESCRIPTION
1	3004464	1	Rack, STIHL® Blower
2	0204300	1	Plug, Plastic Finish, 1" Square Tube
3	3004488	1	Lanyard, 1/16" dia. x 6" w/190 Eyelets
4	3003080	1	Rivet, Pop, 3/16 x 3/16 Steel
5	3004485	1	Pin, Detent, 1/4" Formed
6	-	6	Washer, Flat 3/8 USS Zn
7	-	2	Screw, HHC 3/8-16 x 2-1/2 Gr 5 Zp
8	-	1	Screw, HHC 3/8-16 x 2 Gr 5 Zp
9	-	3	Nut, Nylock 3/8-16 x 7/16 Zn

### WARNING

Check under the trailer and/or fender for locations of brake lines and electrical wiring etc., before drilling any holes. Any damage to trailer during installation is installer's sole responsibility.

of the trailer with a square.

**6.** With the rack clamped into position, drill a 13/32" hole through the center of 1" tube and the trailer rail.

**7.** Fasten rack to the trailer rail with a 3/8-16 x 2" cap screw, two 3/8" flat washers, and a 3/8-16 nylock nut. Tighten all three screws at this time.

## Enclosed Trailer Installation

### Tools Required:

- 9/16" Wrench or Socket
- Electric Drill
- 13/32" & 1/4" Drill Bits
- Hack Saw
- 3/4" Plywood Shim Strips
- Shim Screws

**1.** To maximize floor space in your trailer cut 18" off the bottom of the blower rack with a hack saw.

**2.** Drill two 13/32" holes through the center of the 1" square tube at least 12" apart.

**3.** In order to mount this rack to an enclosed trailer, you must first add 3/4" plywood shim strips to the walls. These shim strips must be attached to at least two wall support studs with suitable fasteners. If you don't know what kind or length of fastener to use contact your trailer dealer or manufacturer for their recommendation.

**4.** Hold the blower rack vertical against the shims and mark the position of the two 13/32" holes.

**5.** Drill two 1/4" pilot holes in the positions just marked for the 3/8" lag screws. Be extremely careful not to drill through the outside trailer wall.

**6.** Fasten the blower rack to the trailer wall with the two 3/8" x 2" lag screws and two 3/8" flat washers supplied.

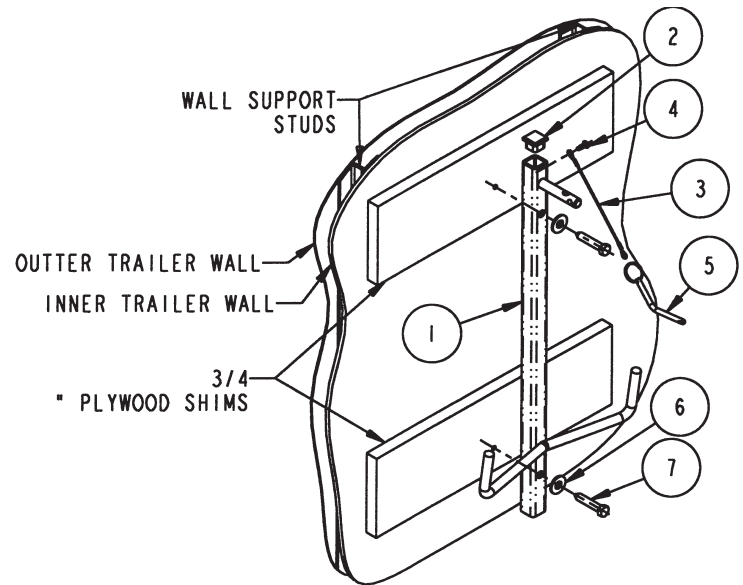

### Bill of Materials

ITEM	PART NO.	QTY.	DESCRIPTION
1	3004464	1	Rack, STIHL® Blower
2	0204300	1	Plug, Plastic Finish, 1" Square Tube
3	3004488	1	Lanyard, 1/16" dia. x 6" w/190 Eyelets
4	3003080	1	Rivet, Pop, 3/16 x 3/16 Steel
5	3004485	1	Pin, Detent, 1/4" Formed
6	-	2	Washer, Flat 3/8 USS Zn
7	-	2	Screw, HHC 3/8-16 x 2-1/2 Gr 5 Zn

### WARNING

**Check under the trailer and/or fender for locations of brake lines and electrical wiring etc., before drilling any holes. Any damage to trailer during installation is installer's sole responsibility.**

### WARRANTY

Buyers Products Co. warrants all truck/trailer hardware manufactured or distributed by it, to be free from defects in material and workmanship for a period of one year from date of shipment. Parts must be properly installed and used under normal conditions. Any product which has been altered, including modification, misuse, accident or lack of maintenance will not be considered under warranty. Normal wear is excluded. The sole responsibility of Buyers Products Co. under this warranty is limited to repairing or replacing any part or parts which are returned, prepaid, and are found to be defective by Buyers Products Co. Authorization from Buyers Products Co. must be obtained before returning any part. No charges for transportation or labor performed on Buyers' products will be allowed under this warranty.