



*Doing Our Best to Provide You the Best*

BC20014, Rev 3  
03/19

---

## **EZ-LATCH COUPLER 2"**

**7,000 - 10,000lb. Rating**

---

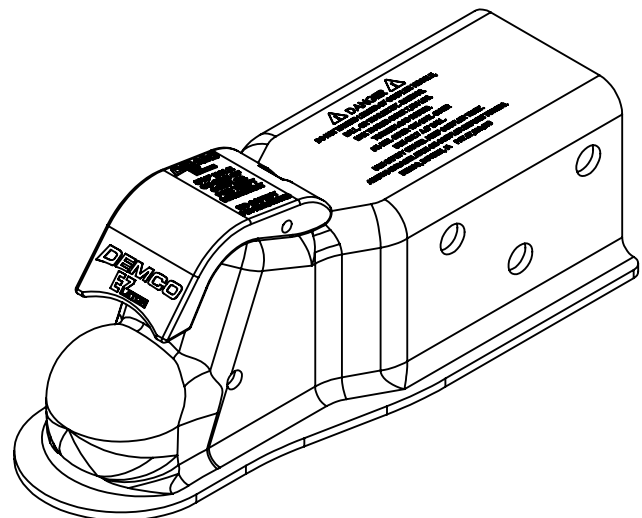
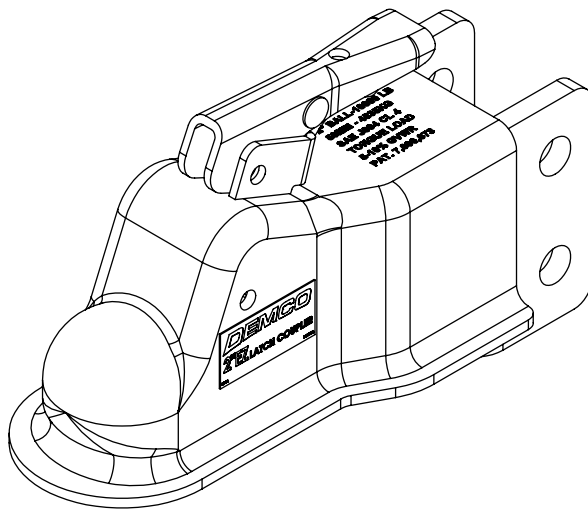

**OPERATOR MANUAL**

# INTRODUCTION

---

## WARRANTY POLICY, OPERATOR MANUALS, PARTS MANUALS & REGISTRATION

Go online to [www.demco-products.com](http://www.demco-products.com) to review Demco warranty policies, operator manuals and register your Demco product.



**WARNING: TO PREVENT SERIOUS INJURY OR DEATH:**

**Review following instructions before installation and use of Couplers.**

**Dealers or distributors must review these instructions with ultimate user.**

**Failure to follow these instructions or failer to properly maintain braking system after installation, can result in loss of braking action.**

## TABLE OF CONTENTS

Introduction and Warranty Policy & Registration .....	2
Safety You Can Live With .....	3-7
Bolt Torque Specifications .....	7
Coupler Configurations .....	8-11

**TAKE NOTE! THIS SAFETY ALERT SYMBOL FOUND THROUGHOUT THIS MANUAL IS USED TO CALL YOUR ATTENTION TO INSTRUCTIONS INVOLVING YOUR PERSONAL SAFETY AND SAFETY OF OTHERS. FAILURE TO FOLLOW THESE INSTRUCTIONS CAN RESULT IN INJURY OR DEATH!**



**THIS SYMBOL MEANS  
ATTENTION  
BECOME ALERT  
YOUR SAFETY IS INVOLVED!**

**SIGNAL WORDS:**

This manual uses the following signal words--**DANGER**, **WARNING**, and **CAUTION**-- with safety messages. The appropriate signal word has been selected using the following guidelines.

**DANGER:**

Indicates an imminently hazardous situation that, if not avoided, will result in death or serious injury. This signal word is to be limited to most extreme situations typically for machine components which, for functional purposes, cannot be guarded.

**WARNING:**

Indicates a potentially hazardous situation that, if not avoided, could result in death or serious injury, and includes hazards that are exposed when guards are removed. It may also be used to alert against unsafe practices.

**CAUTION:**

Indicates a potentially hazardous situation that, if not avoided, may result in minor or moderate injury. It may also be used to alert against unsafe practices.

If you have questions not answered in this manual, require additional copies, or if your manual is damaged, please contact your dealer or DEMCO, 4010 320th Street, Boyden, IA 51234  
ph: (712) 725-2311 or Toll Free: 1-800-543-3626 Fax: (712) 725-2380 or 1-800-845-6420  
<http://www.demco-products.com>



## SAFETY...YOU CAN LIVE WITH IT



### EQUIPMENT SAFETY GUIDELINES

Every year many accidents occur which could have been avoided by a few seconds of thought and a more careful approach to handling equipment. You, the operator, can avoid many accidents by observing the following precautions in this section. To avoid personal injury, study the following precautions and insist those working with you, or you yourself, follow them.

In order to provide a better view, certain illustrations in your owners manual may show an assembly with a safety shield removed. However, equipment should never be operated in this condition. Keep all shields in place. If shield removal becomes necessary for repairs, replace shield prior to use.

Replace any caution, warning, danger or instruction safety decal that is not readable or is missing.

Do not attempt to operate this equipment under the influence of alcohol or drugs.

Review safety instructions with all users annually.

Operator should be a responsible adult. **DO NOT ALLOW PERSONS TO OPERATE OR ASSEMBLE THIS UNIT UNTIL THEY HAVE DEVELOPED A THOROUGH UNDERSTANDING OF SAFETY PRECAUTIONS AND HOW IT WORKS.**

Do not paint over, remove, or deface any safety signs or warning decals on your equipment. Observe all safety signs and practice instructions on them.

Never exceed limits of a piece of machinery. If its ability to do a job, or to do so safely is in question **DON'T TRY IT.**



### REMEMBER

Your best assurance against accidents is a careful and responsible operator. If there is any portion of this manual or function you do not understand, contact your local authorized dealer or manufacturer.



### BEFORE OPERATION:

- Carefully review and follow the installation instructions in this manual.
- Carefully study and understand this manual.
- Always wear protective clothing and substantial shoes.
- Give equipment a visual inspection for any loose bolts, worn parts, or cracked welds, and make necessary repairs. Follow maintenance safety instructions included in this manual.

- Be sure there are no tools lying on or in equipment.
- Do not use equipment until you are sure that area is clear, especially around children and animals.
- Don't hurry learning process or take equipment for granted. Ease into it and become familiar with your new equipment.
- Practice operation of your equipment and its attachments. Completely familiarize yourself and other operators with its operation before using.
- Make sure that brakes are properly adjusted.
- Make sure tow rating on vehicle is high enough for what it is towing. Refer to your towing vehicle Owners Manual.
- Do not allow anyone to stand between tongue or hitch and towing vehicle when backing up to equipment.
- Securely attach to towing vehicle. Use appropriately sized hitch ball and/or hitch pin with a mechanical retainer and attach safety chains.
- Crisscross chains or cables under tongue and secure to draw bar cage, mounting loops or bumper frame.

**DURING OPERATION**

- **SAFETY CHAINS or CABLES:** If equipment is going to be transported on a public highway, safety chains should be obtained and installed. Always follow state and local regulations regarding safety chains and auxiliary lighting. Be sure to check with local law enforcement agencies for your own particular regulations. Only safety chains (not elastic or nylon/plastic tow straps) should be used to retain connection between towing and towed machines in event of separation of primary attaching system. Use a high strength, appropriately sized hitch pin with a mechanical retainer and attach safety chains. Criss cross chains under tongue and secure to draw bar cage, mounting loops, or bumper frame.
- Install safety chains by crisscrossing chains under tongue and secure to draw bar cage, mounting loops, or bumper frame.
- Beware of bystands, **PARTICULARLY CHILDREN!** Always look around to make sure it is safe to start engine of towing vehicle or move equipment. This is particularly important with higher noise levels, as you may not hear people shouting.
- **NO PASSENGERS ALLOWED** - Do not carry passengers anywhere on or in equipment.
- Do not clean, lubricate, or adjust your equipment while it is moving.
- When halting operation, even periodically, set towing vehicles parking brake, shut off engine, and **remove the ignition key.**
- Be extra careful when using on inclines.
- **OPERATE TOWING UNIT CAUTIOUSLY. REDUCE SPEED TO ALLOW FOR ADDITIONAL WEIGHT OF TOWED UNIT.**

- Avoid loose gravel, rocks, and holes, they can be dangerous for equipment operation or movement.
- Allow for overall length when making turns.
- Keep all bystanders and pets clear of work area.
- Operate towing vehicle from operators seat only.
- Never leave running equipment attachments unattended.
- As a precaution, always recheck hardware on equipment following every 100 hours or 50 miles. Correct all problems. Follow maintenance safety procedures.



### FOLLOWING OPERATION

- Following operation, or when unhitching, stop towing vehicle, set brakes, shut off engine and **remove ignition key.**
- Store unit in an area away from human activity.
- Do not permit children to play on or around stored unit.
- Make sure all parked units are on a hard, level surface and engage all safety devices.
- Wheel chocks may be needed to prevent unit from rolling.



### HIGHWAY AND TRANSPORT OPERATIONS

- Adopt safe driving practices:
  - Always drive at a safe speed relative to local conditions, ensure that your speed is low enough for an emergency stop.
  - Reduce speed prior to turns to avoid risk of overturning.
  - Always keep towing vehicle in gear to provide engine braking when going downhill. Do not coast.
  - Do not drink and drive!
- Comply with state and local laws governing highway safety on public roads.
- Use approved accessory lighting, flags and necessary warning devices to protect yourself and operators of other vehicles on highway during transport. Various safety lights and devices are available from your dealer.
- Local laws should be checked for all highway lighting and marking requirements.
- Plan your route to avoid heavy traffic.
- Be a safe and courteous driver. Always yield to oncoming traffic in all situations, including narrow bridges, intersections, etc.

- Be observant of bridge load ratings. Do not cross bridges rated lower than gross weight a which you are operating.
- Watch for obstructions overhead and side to side while transporting.
- Always operate equipment in a position to provide manimum visability at all times. Make allowances for increased length and weight of equipumnt when making turns and/or stopping.



**TORQUE SPECIFICATION**

Torque figures indicated are valid for non-greased or non-oiled threads and heads unless otherwise specified. Therefore, do not grease or oil bolts or capscrews unless otherwise specified in this manual. When using locking elements, increase torque values by 5%.

\* GRADE or CLASS value for bolts and capscrews are identified by their head markings.

**BOLT TORQUE DATA FOR STANDARD NUTS, BOLTS, AND CAPSCREWS.**

Tighten all bolts to torques specified in chart unless otherwise noted. Check tightness of bolts periodically, using bolt chart as guide. Replace hardware with same grade bolt.

NOTE: Unless otherwise specified, high-strength Grade 5 hex bolts are used throughout assembly of equipment.

Bolt Torque for Standard bolts *						
"A"	GRADE 2		GRADE 5		GRADE 8	
	lb-ft	(N.m)	lb-ft	(N.m)	lb-ft	(N.m)
1/4"	6	(8)	9	(12)	12	(16)
5/16"	10	(13)	18	(25)	25	(35)
3/8"	20	(27)	30	(40)	45	(60)
7/16"	30	(40)	50	(70)	80	(110)
1/2"	45	(60)	75	(100)	115	(155)
9/16"	70	(95)	115	(155)	165	(220)
5/8"	95	(130)	150	(200)	225	(300)
3/4"	165	(225)	290	(390)	400	(540)
7/8"	170	(230)	420	(570)	650	(880)
1"	225	(300)	630	(850)	970	(1310)

Bolt Torque for Metric bolts *						
"A"	CLASS 8.8		CLASS 9.8		CLASS 10.9	
	lb-ft	(N.m)	lb-ft	(N.m)	lb-ft	(N.m)
6	9	(13)	10	(14)	13	(17)
7	15	(21)	18	(24)	21	(29)
8	23	(31)	25	(34)	31	(42)
10	45	(61)	50	(68)	61	(83)
12	78	(106)	88	(118)	106	(144)
14	125	(169)	140	(189)	170	(230)
16	194	(263)	216	(293)	263	(357)
18	268	(363)	--	--	364	(493)
20	378	(513)	--	--	515	(689)
22	516	(699)	--	--	702	(952)
24	654	(886)	--	--	890	(1206)

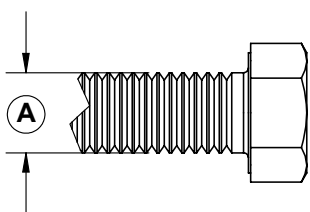

**GRADE-2**

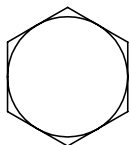

**GRADE-5**

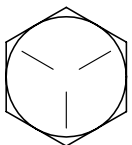

**GRADE-8**

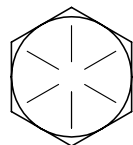

**CLASS 8.8**

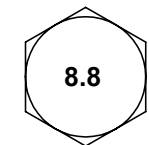

**CLASS 9.8**

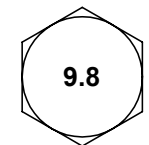

**CLASS 10.9**



# COUPLER CONFIGURATIONS

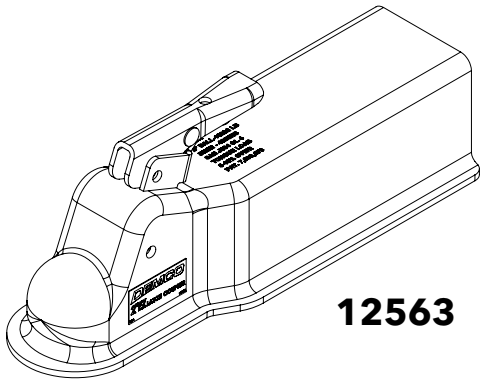

**12563**

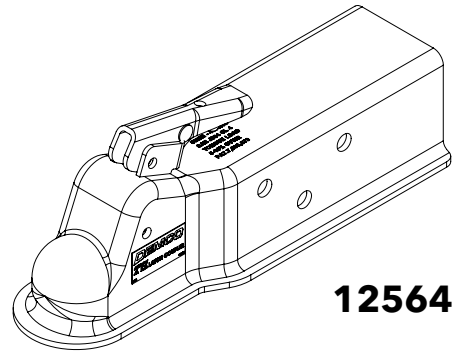

**12564**

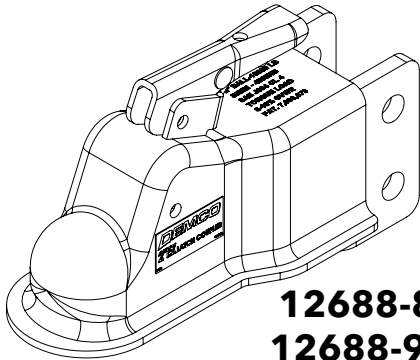

**12688-81**  
**12688-95**

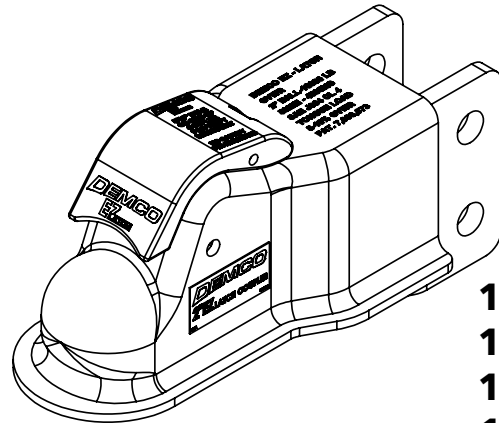

**14976-52**  
**14976-81**  
**14976-95**  
**14976-97**

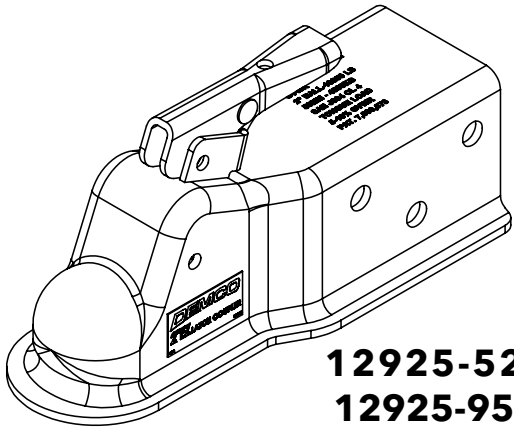

**12925-52**  
**12925-95**

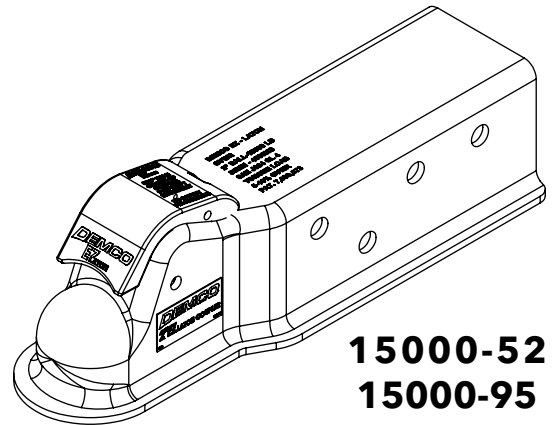

**15000-52**  
**15000-95**

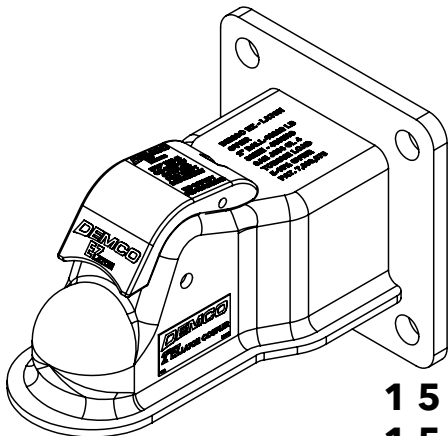

**15080-81**  
**15080-95**  
**15080-97**

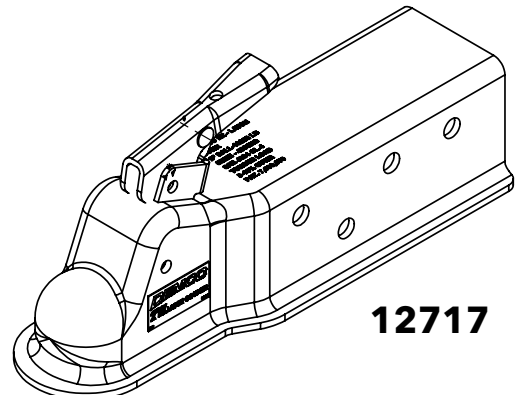

**12717**



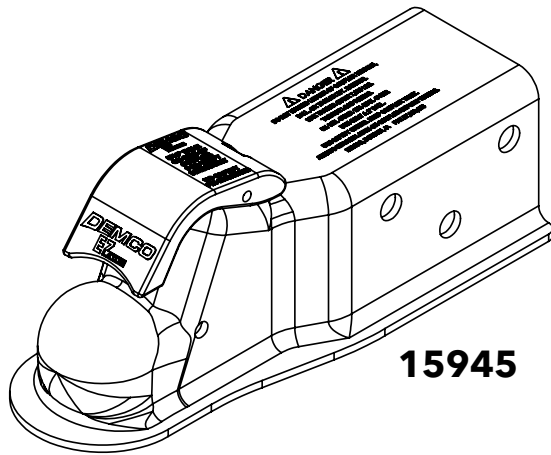

15945

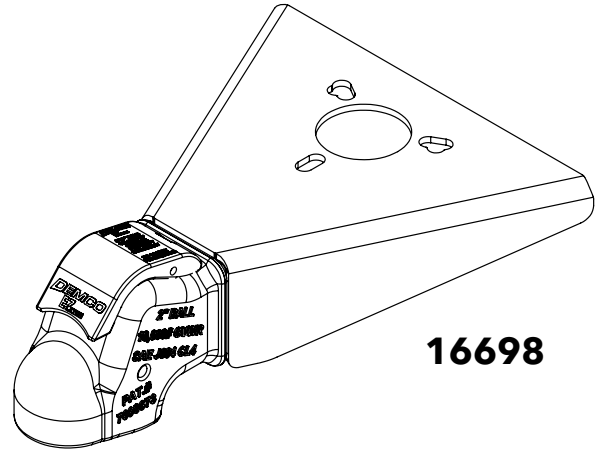

16698

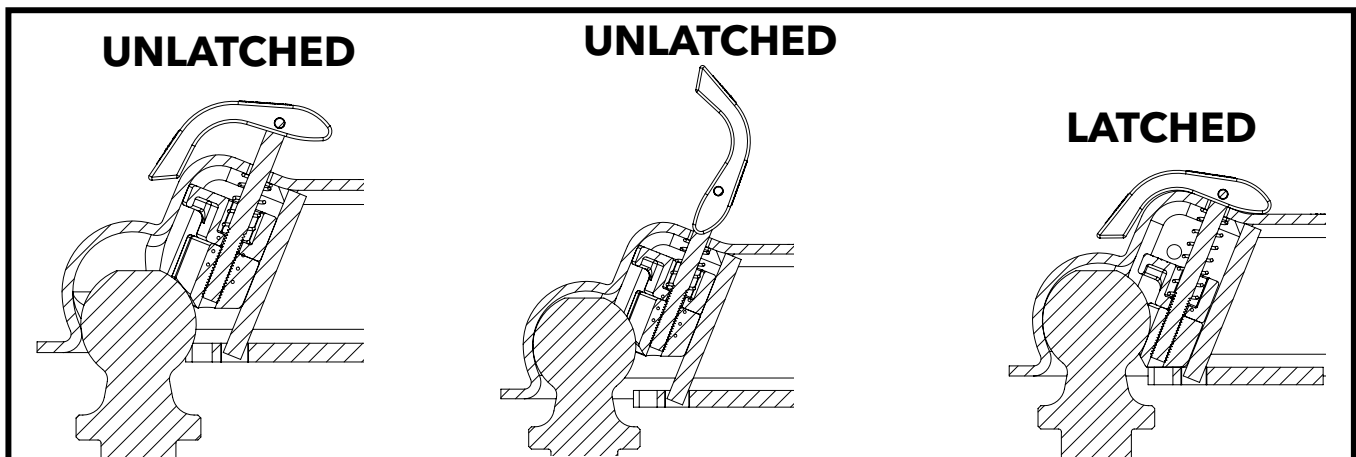

Handle must be facing **FORWARD** and **DOWN** to latch coupler to ball.

Lock pin must be removed for eZ-Latch feature to work.



**WARNING**

- **Always** make sure coupler is properly latched onto correct size ball before towing
- **Criss cross** safety chains or cables to towing vehicle
- **Make sure** lights are hooked up and working properly
- **Do NOT** exceed lesser of coupler, vehicle ball or trailer weight rating
- **Check** with tow vehicle manufacture for tow ability and recommendations
- **All** Demco eZ-Latch couplers are tested & rated without the use of a safety pin

# BOLT ON CONFIGURATIONS

2" & 2-5/16" Tube Mount

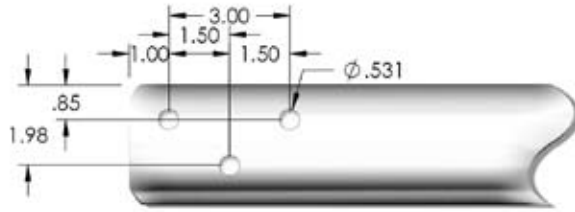

Flat Mount

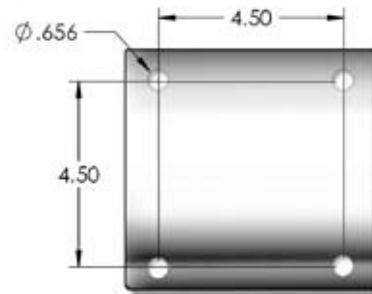

2" & 2-5/16" Tube Mount

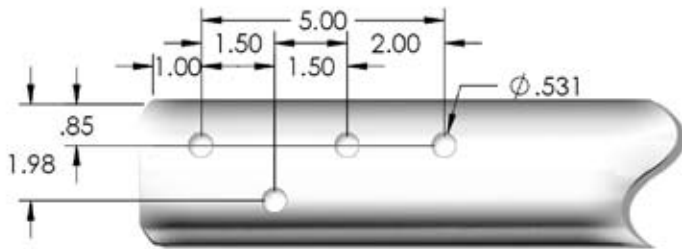

## WELDING

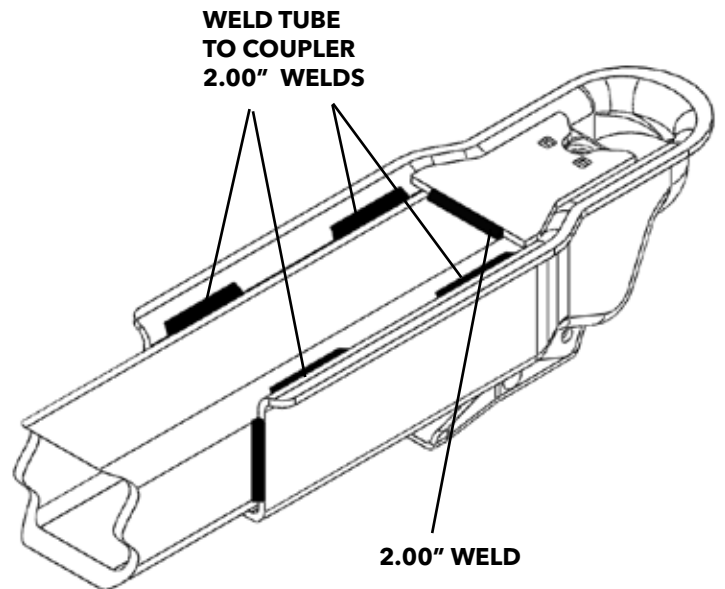
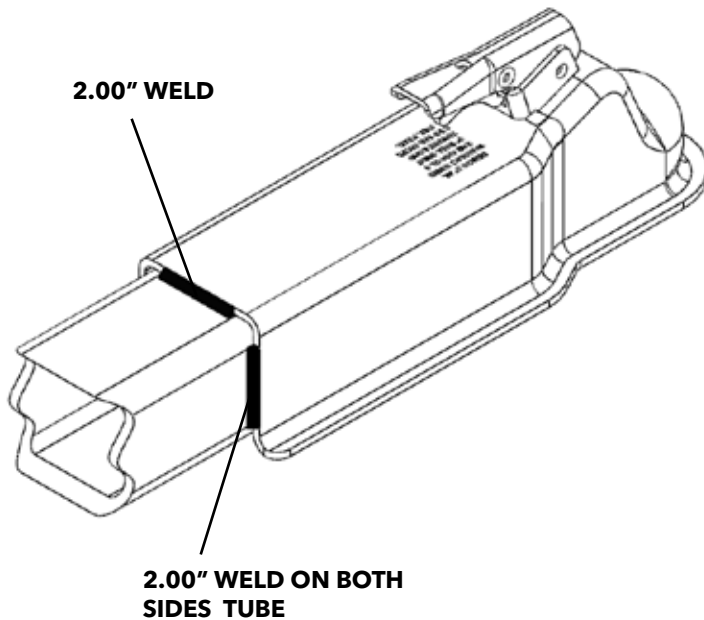



**WARNING: To Avoid Personal Injury or Property Damage, Observe The Following Instructions:**

The weight rating of the coupler is dependent on the correct bolts being used. You must use the exact size, grade and number of bolts as specified in your manual. Mounting hardware can be obtained from Demco.



**WARNING: The attachment of this product is critical and beyond the control of DEMCO.**

DEMCO is NOT responsible for the attachment nor the installation. It neither guarantees, nor will it be liable for any damages resulting from its attachment or improper use. The liability of this product is limited to purchase price if it proves to be defective in material and or workmanship. Warranty information available upon request. Warranty void if hardware is damaged or worn.

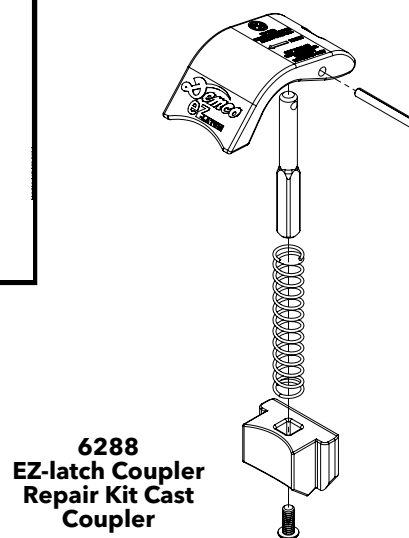
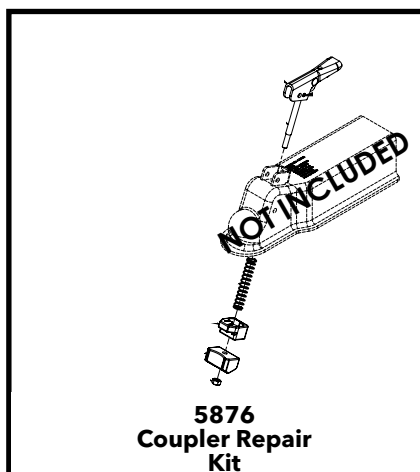
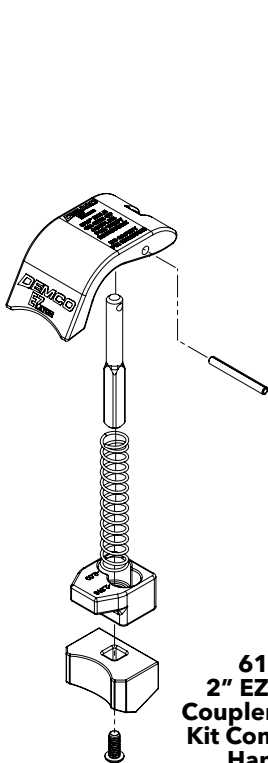
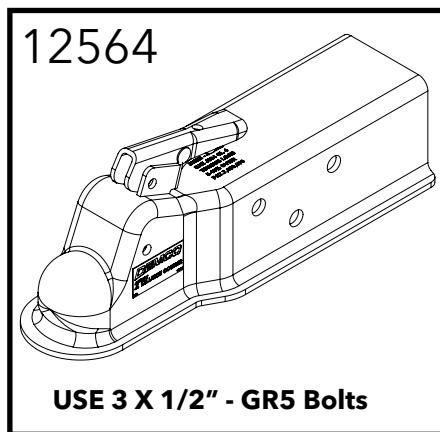
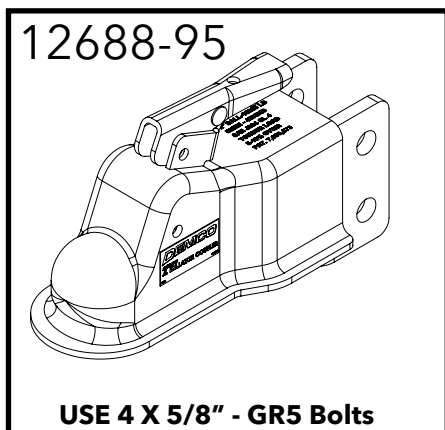

# **DEMCO**

4010 320th St., Boyden, IA. 51234

Phone: (712) 725-2311

Fax: (712) 725-2380

Toll Free: 1-800-54DEMCO (1-800-543-3626)

**Demco warranty policies, operator manuals, and product registration  
can be found online:**

**[www.demco-products.com](http://www.demco-products.com)**

